

**RULES AND REGULATIONS  
FOR  
WATER AND WASTEWATER SERVICE**



**EAGLE RIVER  
WATER & SANITATION  
DISTRICT**

---

**APPENDIX B**

**WATER AND WASTEWATER SERVICE  
CONSTRUCTION SPECIFICATIONS**

---

Last Approved Revision: January 25, 2018

**TABLE OF CONTENTS**

**SECTION I – GENERAL ..... 3**

1.1 AUTHORITY ..... 3

1.2 DEVELOPMENT APPROVAL AND INFRASTRUCTURE ACCEPTANCE ..... 3

1.3 VARIANCE ..... 3

1.4 PURPOSE ..... 4

1.5 AUTHORIZATION TO CONNECT ..... 4

1.6 SERVICES AND METERS ..... 4

1.7 SCHEDULING INSPECTIONS ..... 4

1.8 JOINT SERVICE LINES ..... 5

1.9 STUB OUTS ..... 5

**SECTION II – WASTEWATER SERVICES..... 6**

2.1 PIPE MATERIAL ..... 6

2.2 SEPARATION OF SERVICES ..... 6

2.3 SERVICE LINE DESIGN ..... 7

2.4 UNDERGROUND WARNING TAPE ..... 7

2.5 BEDDING MATERIAL..... 7

2.6 SERVICE CONNECTION TO MAIN..... 7

2.7 STUB OUTS..... 8

2.8 CONNECTIONS, TESTING AND REQUIREMENTS FOR INSPECTION ..... 8

2.9 REPAIR COUPLINGS..... 8

2.10 PROHIBITED DISCHARGES..... 8

**SECTION III – WATER SERVICES..... 9**

3.1 MATERIALS ..... 9

3.2 BURIAL DEPTH ..... 10

3.3 UNDERGROUND WARNING TAPE ..... 11

3.4 FIRE SYSTEM SERVICES ..... 11

3.5 SEPARATION OF SERVICES ..... 11

3.6 SERVICE ALIGNMENT ..... 11

3.7 CURB STOP LOCATION ..... 11

3.8 CONNECTIONS, TESTING AND REQUIREMENTS FOR INSPECTION ..... 11

3.9 METER ASSEMBLIES ..... 13

3.10 STOP AND WASTE VALVES..... 14

3.11 METER PITS..... 14

3.12 REPAIR COUPLINGS..... 15

**SECTION IV-STANDARD SERVICE LINE DETAILS..... 16**

FORM B-01: WATER SERVICE STUB OUT ..... 17

FORM B-02: WATER SERVICE TAPPING DETAIL ..... 18

FORM B-03: SERVICE LINE METER VAULT..... 19

FORM B-04: METER ASSEMBLY DIAGRAM ..... 20

FORM B-05: SEWER SERVICE CONNECTION..... 21

## **SECTION I – GENERAL**

---

### **1.1 Authority**

The Standard Specifications for Water and Wastewater Service Construction as set forth herein (“Specifications”) are promulgated by the following: Arrowhead Metropolitan District, Bachelor Gulch Metropolitan District, Beaver Creek Metropolitan District, Berry Creek Metropolitan District, Cordillera Metropolitan District, Eagle River Water & Sanitation District, EagleVail Metropolitan District, Edwards Metropolitan District, Town of Avon, Traer Creek Metropolitan District (Village at Avon), and Upper Eagle Regional Water Authority (“District”). The interpretation and enforcement of said Specifications is hereby delegated to the Regulations Administrator of the Eagle River Water & Sanitation District.

#### **1.1.1 Effective Date of Specifications**

The Specifications shall become effective immediately upon formal adoption by the District and shall supersede all former specifications for water main construction. The most current version of these Specifications is available at [www.erwsd.org](http://www.erwsd.org)

#### **1.1.2 Revisions, Reference, Amendments, or Additions**

The Specifications may be revised and/or amended. Such revisions, amendments, and additions shall be binding and in full force immediately upon formal adoption by the District.

The latest edition of the International Plumbing Code (IPC) is incorporated herein by reference. In cases where conflicts arise between these Specifications and IPC, the more stringent shall prevail.

#### **1.1.3 Definitions**

Please reference the Rules and Regulations for Water and Wastewater Service, Article II.

### **1.2 Development Approval and Infrastructure Acceptance**

Please reference the Rules and Regulations for Water and Wastewater Service, Articles VIII and IX, respectively.

### **1.3 Variance**

The District recognizes that the strict and literal interpretation of these Rules and Regulations may not be possible in all cases. Please refer to Article VII for information on the Variance process.

#### **1.4 Purpose**

These Water and Wastewater Service Construction Specifications are intended to insure that the Services extended from the Water System and Wastewater System is constructed so as to not adversely impact the Water System or Wastewater System.

#### **1.5 Authorization to Connect**

This Appendix provides construction specifications, including testing and inspection requirements related to Services, but does not include all of the requirements for Connection to the Water and/or Wastewater Systems. Customers intending to make a Connection must contact the District prior to any construction or work on the Water Service or Wastewater Service so that all requirements for Connection can be determined. A complete description of the requirements for Connection can be found in these Rules and Regulations, refer to Article IV, Authorization to Connect to Water and Wastewater Systems.

Customers must submit a completed Connection Application (available at [www.erwsd.org](http://www.erwsd.org)) and a Water and Wastewater Service construction plan to the District prior to any work to construct the Services.

#### **1.6 Services and Meters**

Each separately metered unit shall have a separate and independent Water and Wastewater Service Connection to the Main. Meter installation must be in strict conformance with the standard Meter installation details shown in Detail B-04. If requested by the District on a case-by-case basis, the customer shall submit a Meter Entry Diagram for review and approval along with the Connection Application prior to installation of meter. Meter Size and type are determined by the District after submittal of meter sizing form.

#### **1.7 Scheduling Inspections**

The Customer shall notify the District when the Water or Wastewater Service is ready for inspection or Connection to the Water or Wastewater Main. Appointments for inspections, testing, Connection, meter inspection, Turn-On, Turn-Off or operation of Water Main valves must be scheduled with the District a minimum of two (2) business days in advance.

## **1.8 Joint Service Lines**

Joint service lines are discouraged, but if allowed, must have a recorded maintenance and ownership agreement with Eagle County or have language in the HOA Documents to the same effect. ERWSD is not responsible for the maintenance of private service lines.

## **1.9 Stub Outs**

Stub outs are for the benefit of the property and are not guaranteed to exist; the location and depth may or may not be known.

## SECTION II – WASTEWATER SERVICES

---

### 2.1 Pipe Material

#### **A. Polyvinyl Chloride (PVC) non-pressure:** SDR-35/SDR-26

4 to 8 inches (4" to 8"): ASTM D3034, SDR-35/PS46 or ASTM D3034, SDR-26/PS115

Maximum pipe length shall be 20 feet (20'). Joint lubricant shall be supplied by the pipe manufacturer. Joint lubricant shall be non-toxic and water-soluble.

**B. Polyvinyl Chloride (PVC) pressure:** Yelomine: SDR-21, Restrained joint PVC pressure pipe and fittings having a minimum cell classification of 12454, as defined in ASTM D1784. Conform to ASTM D2241 "Standard Specifications for PVC, pressure rated pipe, 200 psi (SDR Series)."

AWWA C-900 for 4 " through 8" diameter pipe, pressure class 235 psi, DR18, with push-on joints and flexible elastomeric seals ASTM D3139/ASTM F477. All spigot ends shall be beveled to manufacturer's specifications with gaskets meeting ASTM F477 and joints in compliance with ASTM D3139.

For 1 ½" service lines utilizing an ejector pumping system, either Polyethylene (PE) or PVC shall be used. PE piping shall be AWWA C901, pressure class 150 psi. Joints shall be fusion type in accordance with AWWA C901. PVC shall be schedule 80 meeting the requirements of ASTM D1785, with solvent welded, socket type fitting meeting the requirements of ASTM D2467.

**C. Ductile Iron:** Pipe per ASTM A746, Class 52, 350 psi, AWWAC151. Push-on joints per ANSI/AWWA C111/A21.11. Factory applied Protecto 401, or equivalent, ceramic epoxy interior lining for DIP & fittings. U.S. Pipe and Foundry Company/Griffin Pipe Products or approved equal.

**D. Service Line Taps:** Factory wyes shall be used for all service line connections with new gravity main line installations. See Appendix B, Section 2.6 for requirements for new service line connections to existing mains.

### 2.2 Separation of Services

At least ten (10) feet of horizontal separation must be maintained between parallel Water and Wastewater Services. If at least ten (10) feet of horizontal separation cannot

## SECTION II – WASTEWATER SERVICES

be maintained between parallel Water and Wastewater Services, the Wastewater Service must be constructed of C900 PVC pipe with integral bell and spigot joints or, SDR 21 Certa-Lok Yelomine with tracer wire, PVC pipe with gasketed joints. District authorization must be obtained to install Water and Wastewater Services with less than ten (10) feet of horizontal separation. Water and wastewater service lines shall not cross.

### **2.3 Service Line Design**

The Wastewater Service gravity piping shall be four (4) inch or greater in diameter. If the service line is pressurized via lift station or ejector system, the service line shall be designed by an Engineer and submitted with the Connection Application for review and approval by the District. Gravity wastewater services shall be installed at a constant grade of not less than one quarter ( $\frac{1}{4}$ ) inch per foot, with a minimum of bends and no glue joints. Clean Outs should be installed every 100 feet, at every change of direction greater than 45 degrees, and a maximum of three (3) feet from the face of the building. Wastewater Service piping shall be buried a minimum of four feet six inches (4' 6") below the ground surface. If minimum bury depth cannot be achieved, insulation is required per Appendix D. A depth of bury greater than fifteen (15) feet requires the approval of the District.

### **2.4 Underground Warning Tape**

Underground Warning Tape shall be installed twenty four inches (24") above all buried portions of the Wastewater Service. The tape shall meet the following requirements:

- (a) Five (5) mil thick Polyethylene tape
- (b) Solid green color with black lettering
- (c) Six (6) inches in width

### **2.5 Bedding Material**

Refer to Appendix E, Earthwork.

### **2.6 Service Connection to Main**

The connection of the Wastewater Service to the Wastewater Main shall be made as follows:

- (a) A factory wye shall be installed on all new mainline installations for service line stubouts on gravity mains. A saddle tap, provided by the District, shall be used on new service line connections to existing mainlines. All service connections shall be above spring line.

## SECTION II – WASTEWATER SERVICES

- (b) On four inch (4") or six inch (6") diameter new service connections to existing mains, a saddle connection is required. The saddle connection shall be located no closer than ten (10) feet from a manhole. The flow line of the Service pipe shall enter the Main above the spring line of the Main. Connections into manholes are prohibited. All Connections up to six (6) inches in diameter shall be made by District personnel.
- (c) If the Service pipe is eight (8) inches or greater in diameter, the connection shall be made into an existing manhole or into a new manhole placed on the existing Main. Connections eight (8) inches or greater in diameter shall be made by a qualified contractor on behalf of the Customer and witnessed and inspected by a District Inspector.

### **2.7 Stub Outs**

If a Stub Out pre-exists on a property and will not be utilized by the Customer, the Stub Out must be abandoned by the Customer by capping the service at the main. The abandonment shall be inspected by the District prior to backfill. The use of a Stub Out for Connection to the Wastewater Main must be approved by the District.

### **2.8 Connections, Testing and Requirements for Inspection**

No Services shall be covered with bedding material or backfill without the District Inspector's approval. All portions of the Wastewater Service must be visible to the District Inspector for an inspection to be completed.

### **2.9 Repair Couplings**

Repair Couplings on a wastewater service line must be compatible with the Sewer Service pipe, installed per the manufacture's specifications and inspected by District personnel.

### **2.10 Prohibited Discharges**

Floor drains and garage drains shall not be connected to the Wastewater System without written permission from the District. Please refer to Article VI of the Rules and Regulations.



## SECTION III – WATER SERVICES

---

### 3.1 Materials

#### 3.1.1 General Requirements

The District follows the CDPHE lead-free policy. No metals that may cause lead or lead leaching such as galvanized pipe are allowed.

The joining of dissimilar metals in water service lines is prohibited.

#### 3.1.2 Copper Tubing

Copper Water Services shall be 1", 1.5" or 2" diameter seamless Type K copper tubing in accordance with ASTM B88. Connections shall be compression in accordance with ANSI/AWWA C800 or silver soldered conforming to AMS 4773C. All shall be certified to comply with NSF/ANSI 61, NSF/ANSI 61 Annex G, and NSF/ANSI 372. No lead solder joints shall be allowed. All copper service lines must use full lengths of tubing (i.e. 100' for 1", 60' for 1.5" and 40' for 2") before a splice can be installed.

Installed Type K copper tubing shall be free of kinks, indentations, and damaged areas. Any damaged copper tubing or fittings may be rejected by the District Inspector.

An appropriate size gooseneck shall be made in the Water Service at the corporation valve to prevent the Service from being pulled from the Water Main during backfill and compaction operations.

#### 3.1.3 Polyethylene Tubing (PE)

Polyethylene tubing used for water services shall meet the requirements of AWWA C901, shall be 3608 high density resin material and conform to ASTM standards listed for water service pipe in the latest edition of the IPC. All joints shall be brass compression grip ring type with stainless steel inserts or fused. Polyethylene tubing shall have a pressure rating of 200 psi. All polyethylene service lines must use full lengths of tubing (i.e. 300' for 1", 250' for 1.5" and 200' for 2") before a splice can be installed.

A tracer wire, 10-gauge, shall be taped to the Water Service at every two (2) feet from the corporation valve to the inside of the structure, that is brought up to the surface at the Curb Stop valve. Wire connections shall be wax taped for corrosion protection.

All Water Services between the corporation valve and the Curb Stop valve shall be constructed of Type K copper in accordance with 3.1.2.

### **3.1.4 Ductile Iron Pipe (DIP)**

Water services greater than or equal to four (4) inches in diameter and be constructed of ductile iron pipe, AWWA Class 52, with a pressure rating of 350 psi. Services to be constructed of ductile iron pipe must be designed by a licensed engineer and construction plans must be submitted to the District for approval.

A tracer wire, 10-gauge, shall be taped to the Water Service at every two (2) feet from the water main to the Curb Stop valve. Wire connections shall be wax taped for corrosion protection. Refer to detail B-02.

### **3.1.5 Corporation Stops**

Corporation stops shall be constructed of all brass construction with threaded taper or IP thread inlet and grip compression connection out in accordance with ANSI/AWWA C800 and conform to ASTM B584, UNS C89833 (latest revision). Corporation stops shall be Mueller 300 Ball Type Corporation Valve, Catalog Number B-25008N or B25028N or approved equal.

### **3.1.6 Curb Stops**

Curb stops shall be of all brass construction with compression connections for inlet and outlet in accordance with ANSI/AWWA C800 and conform to ASTM B584, UNS C89833 (latest revision). Curb stops shall be Mueller 300 Ball Curb Valve No. B25209N, or approved equal.

### **3.1.7 Curb Boxes**

Curb boxes shall be cast iron in accordance with ASTM A 48, Class 35B. For curb stops up to 1", curb boxes shall be Mueller H10314 with 89982 lid and stationary rod, part number 828- series, depending on final bury depth. For curb stops larger than 1", the curb boxes shall be Mueller H10336 with 89982 lid.

### **3.1.8 Saddles**

Tapping saddles shall be Mueller BR2S or BR2W, AWWA C800, brass body, 200 psi maximum working pressure, double strap design, with optional 304L stainless steel straps.

## **3.2 Burial Depth**

Water Services shall be buried a minimum of seven (7) feet and a maximum of nine and a half (9.5) feet below the ground surface.

### **3.3 Underground Warning Tape**

Underground warning tape shall be installed twenty four inches (24”) above all buried portions of the Water Service. The tape shall meet the following requirements:

- (a) Four (4) mil thick Polyethylene tape
- (b) Solid blue color with black lettering
- (c) Six (6) inches in width

### **3.4 Fire System Services**

Commercial Water Service connections for fire suppression systems shall be as required by the local fire authority. Residential connection of the fire suppression system to the Water Service shall occur downstream from the Curb Stop valve and upstream of the meter. Refer to Detail B-04.

### **3.5 Separation of Services**

A horizontal separation of ten (10) feet must be maintained between parallel Water and Wastewater Services. Water and Wastewater Services shall not cross.

### **3.6 Service Alignment**

The alignment of the Water Service shall take the shortest, most direct route from the Water Main to the Water Meter.

### **3.7 Curb Stop Location**

The Curb Stop shall be located a maximum of one (1) foot within the property line or edge of easement, and shall be easily accessible to District personnel. Refer to curb stop detail B-01 for services less than or equal to 2” and B-02 for services greater than or equal to 4”.

### **3.8 Connections, Testing and Requirements for Inspection**

All Water Service connections of 1", 1.5" and 2 inch diameter shall be made only by District personnel using a tapping saddle fitting on existing mains. Water Service Connections 4 inch (4”) in diameter or greater shall be made by a qualified contractor on behalf of the Customer, and witnessed and inspected by a District Inspector. For all connections 4" in diameter and larger, a tee shall be installed on the main or a wet tap may be made using a tapping sleeve with prior approval from the District. The tapping sleeve shall be stainless steel Mueller H304 (250 psi working pressure) or approved equivalent. The use of a tapping sleeve shall meet the following conditions:

### SECTION III – WATER SERVICES

- (a) Tapping sleeve must be approved by the District prior to installation, and may only be installed by an approved contractor
- (b) System working pressures shall not exceed the tapping sleeve's rated working pressure
- (c) Tapping sleeves shall not be permitted for service lines with a diameter that is larger than or equal to one-half ( $\frac{1}{2}$ ) the diameter of the main being tapped.
- (d) Tapping sleeves shall not be permitted for service connections larger than 6" in diameter. A tee shall be installed on the Water Main.

No Services shall be covered with bedding material or backfill without the District Inspector's approval. All portions of the Water Service must be visible to the District Inspector for an inspection to be completed.

*Service lines four inches (4") or larger in diameter:*

The District Inspector will perform high chlorine, low chlorine, bacteriologic, and hydrostatic testing on the Service, similar to a water main. Details of the testing procedures can be found in Appendix C, Section 5. Customer shall provide a minimum of two days advance notice to schedule testing. The testing process typically requires a minimum five day duration before water service can be turned on. Failure to pass these tests will result in the Customer flushing the Service and the District retesting the Service.

*Service Lines smaller than four inches (4"):*

No disinfection is required on service lines smaller than 4". Hydrostatic testing of the service line shall use system pressure. The contractor shall backfill the trench at their own risk. Pressure is held for a minimum of two hours and will be accepted if no leaks are measured or observed. If the test fails, the service line will need to be repaired or replaced. In winter conditions, compressed air may be used for testing at the discretion of the District Inspector.

District personnel must attend all underground Fire Protection Service flush tests in order to operate Curb Stop valves. District shall be notified a minimum of two business days prior to testing.

Customers requesting Connections after November 15 and before April 15 must provide heating, adequate to prevent freezing of water, in the Connecting area.

### **3.9 Meter Assemblies**

The following criteria dictate the design and installation of commercial and residential meter assemblies. A meter assembly consists of a pressure reducing valve, shutoff valves, backflow prevention device, water meter, and related appurtenances. All meter assemblies shall be design and constructed per most recently adopted plumbing codes.. Please refer to Detail B-04 for a schematic of the approved meter assemblies.

#### **3.9.1 Pressure Reducing Valve (Domestic)**

A pressure-reducing valve (PRV) shall be installed on all Water Services upstream of the water meter, ensuring that the water meter and the building plumbing system are protected from fluctuating water system pressures. Water Service will not be turned on until the meter assembly including the PRV is installed. The pressure setting of the PRV shall not exceed 100 psi without written permission from the District. Customers are responsible for ownership, maintenance and operation of Pressure Reducing Valves. The district recommends periodic inspection and maintenance per the manufacturer's recommendations.

#### **3.9.2 Pressure Reducing Valve (Fire Suppression System)**

A pressure-reducing valve (PRV) shall be installed on all fire sprinkler systems to ensure that they are protected from fluctuating water main pressures. The pressure setting of the PRV shall not exceed 200 psi without written permission from the District. Customers are responsible for ownership, maintenance and operation of Pressure Reducing Valves. The district recommends periodic inspection and maintenance per the manufacturer's recommendations.

#### **3.9.3 Shutoff Valves**

A shut-off valve shall be installed upstream of the PRV. Additionally, a shut-off valve shall be installed downstream of the backflow preventer isolating the meter assembly to facilitate repairs.

#### **3.9.4 Backflow Prevention Devices**

Backflow prevention devices are required on all Water Services. Refer to Appendix G of these Rules and Regulations for Backflow Prevention regulations.

#### **3.9.5 Water Meter**

All domestic connections to the District's Water System shall include a Water Meter. The meter type and size shall be determined by the District. The District will provide the Customer with a meter once the Customer has paid the appropriate meter fee.

The Customer shall install the meter per the specifications below.

- (a) The location of the meter is subject to District approval. The meter location shall be adequately insulated to protect from freezing, fully accessible, adequately

ventilated, well-lit, and shall not meet the definition of confined space, as defined by the Occupational Safety and Health Administration (OSHA), unless approved by the District. The design of meter pits must be approved by the District and shall be in conformance with Section 3.11. Meters in crawl spaces are not recommended. Crawl space meter installations are subject to prior approval by the District's meter technician. Any meter installation in a crawl space must have adequate lighting, adequate working room, and be within (3) feet of the opening.

- (b) The District shall inspect the installation of all water meters. The Customer will be provided with a three-strand wire for installation of a transmitter. Prior to meter inspection and water Turn-On, the Customer shall install the meter assembly and the wire from the meter location to an appropriate transmitter installation site. The transmitter will be located five (5) feet above ground in an accessible location free from snow that will provide year-round access for District personnel. The maximum distance from the meter to the transmitter shall not exceed one hundred (100) feet without approval of the District. Meters shall be installed in a horizontal position unless manufacturer specifications allow. The Meter shall be no higher than three (3) feet above and no lower than six (6) inches above the floor, as measured from the bottom of the Meter.
- (c) The Customer is solely responsible for protecting the meter from freezing, or any other physical damage.

Water will remain turned off until the District accepts payment of all Connection fees.

### **3.9.6 Bypass Piping on Commercial Meters**

All water meters greater than 1.5 inch in size and serving six (6) or more Residential Units, mixed commercial/residential developments, or a commercial development shall be installed with a bypass line equipped with isolation valves to allow for maintenance of the meter without interruption of water service to the Customer. The bypass line will be unmetered and secured with a District padlock. Refer to Detail B-04.

### **3.10 Stop and Waste Valves**

Stop and waste valves are prohibited.

### **3.11 Meter Pits**

Meter pits shall be adequately sized to contain the meter assembly and allow for maintenance of the assembly. Meters will be required to be installed in a precast concrete manhole with an overall depth of 84 inches.

Meter pits shall be installed at the property line or the edge of easement, and downstream of the Curb Stop valve. A 5' high 4" x 4" post shall be provided for the Radio Transmitter Unit. A 3-strand wire provided by the District shall be run from the meter to the top of the post. Refer to Detail B-03.

**3.11.1 Manhole Bases**

Precast concrete, ASTM C478, minimum 48-inch diameter or District approved alternative.

**3.11.2 Manhole Sections**

Precast concrete, ASTM C478, with the inside lip higher than the outside lip , minimum 48-inch diameter or District approved alternative. Concrete cone sections shall be eccentric.

**3.11.3 Manhole Rings and Covers**

For installations located in public rights of way manhole rings and covers shall be cast iron, ASTM A48, with a flat lid with the lettering "WATER" cast on the cover. Ring and cover combined weight shall be greater than 255 pounds and machined to fit securely with a non-rocking cover. Lid shall be waffle patterned, and able to withstand HS-20 traffic loading.

**3.11.4 Manhole Steps**

For concrete manholes only, non-skid steps shall be installed capable of carrying a load of 1,000 pounds, installed six (6) inches from the face of the manhole. The steps shall conform to ASTM C478 and be plastic coated.

**3.11.5 Manhole Joint Sealant**

Double RUBR-NEK LTM butyl rubber flexible gasket-type sealant shall be applied to all manhole joints with RUB'R-NEK primer. One (1) inch on 48-inch diameter manholes; 1.5 inch on all larger sizes.

**3.12 Repair Couplings**

Repairs to Water Services located between the curb stop and the structure that require couplings shall be made only by the use of a silver-soldered joint and shall be inspected and approved by the District prior to backfill.

## **SECTION IV-STANDARD SERVICE LINE DETAILS**

---

**Form B-01: Water Service Stub Out**

**Form B-02: Water Service Tapping Detail**

**Form B-03: Service Line Meter Vault**

**Form B-04: Meter Assembly Diagram**

**Form B-05: Sewer Service Connection**



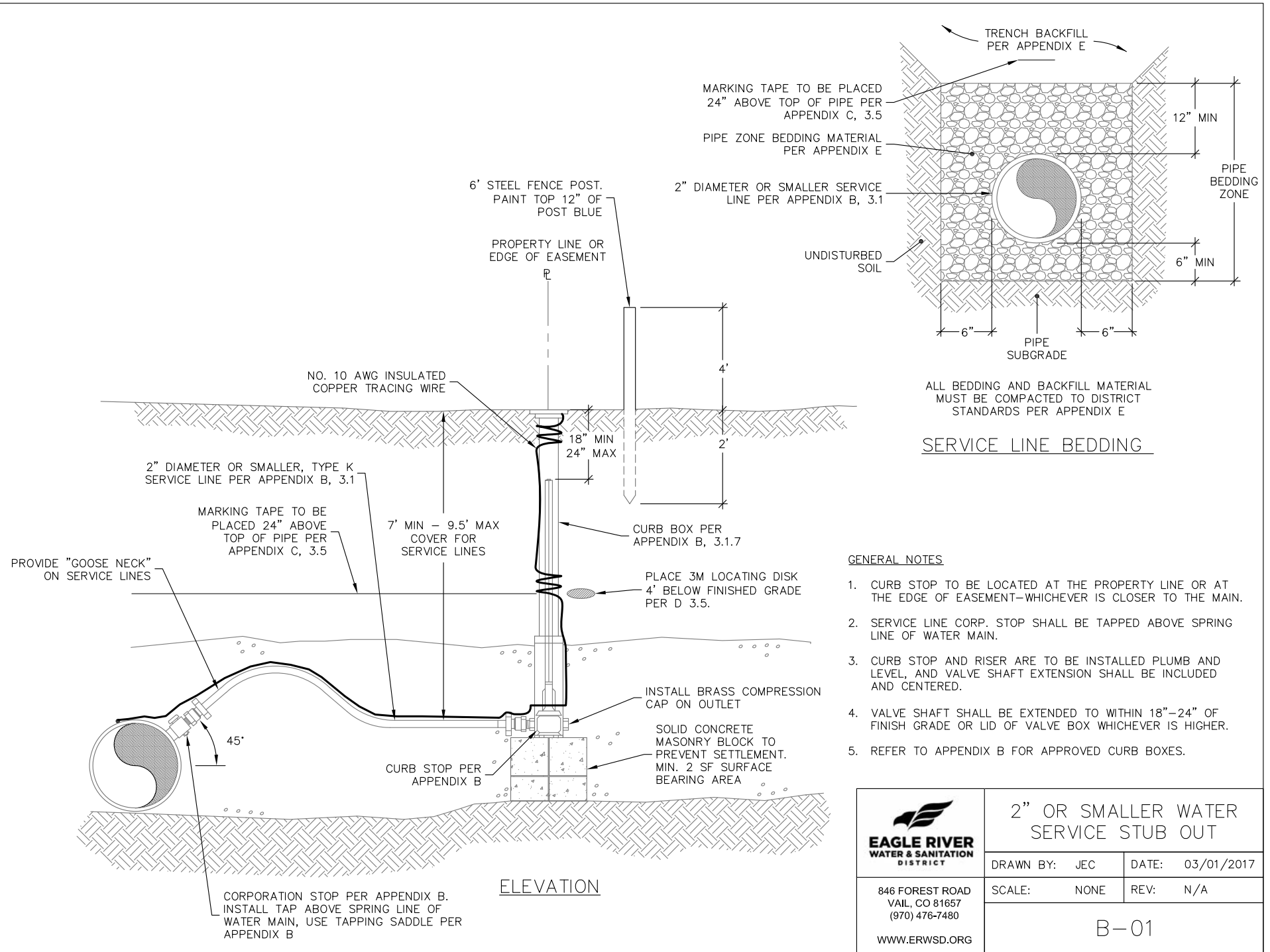

**GENERAL NOTES**

1. CURB STOP TO BE LOCATED AT THE PROPERTY LINE OR AT THE EDGE OF EASEMENT—WHICHEVER IS CLOSER TO THE MAIN.
2. SERVICE LINE CORP. STOP SHALL BE TAPPED ABOVE SPRING LINE OF WATER MAIN.
3. CURB STOP AND RISER ARE TO BE INSTALLED PLUMB AND LEVEL, AND VALVE SHAFT EXTENSION SHALL BE INCLUDED AND CENTERED.
4. VALVE SHAFT SHALL BE EXTENDED TO WITHIN 18"–24" OF FINISH GRADE OR LID OF VALVE BOX WHICHEVER IS HIGHER.
5. REFER TO APPENDIX B FOR APPROVED CURB BOXES.

 <p><b>EAGLE RIVER</b> WATER &amp; SANITATION DISTRICT</p>	<p>2" OR SMALLER WATER SERVICE STUB OUT</p>	
	<p>DRAWN BY: JEC</p>	<p>DATE: 03/01/2017</p>
<p>846 FOREST ROAD VAIL, CO 81657 (970) 476-7480</p>	<p>SCALE: NONE</p>	<p>REV: N/A</p>
<p>WWW.ERWSD.ORG</p>		<p>B-01</p>

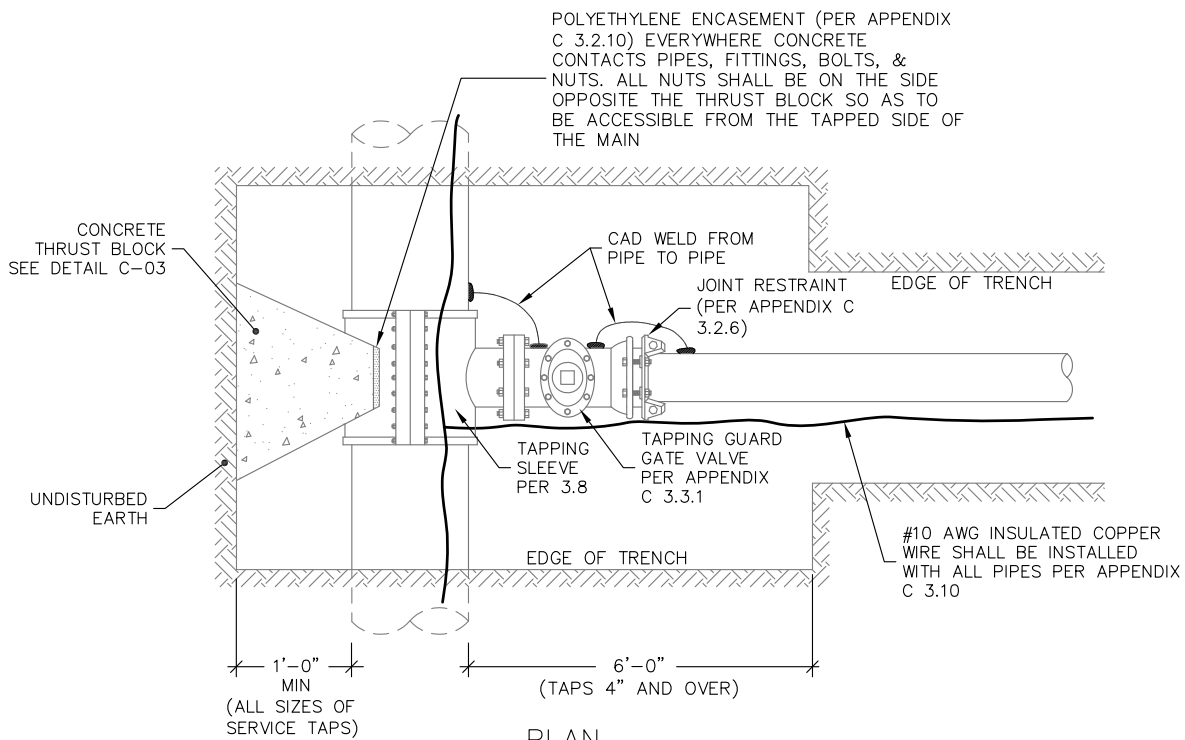

PLAN

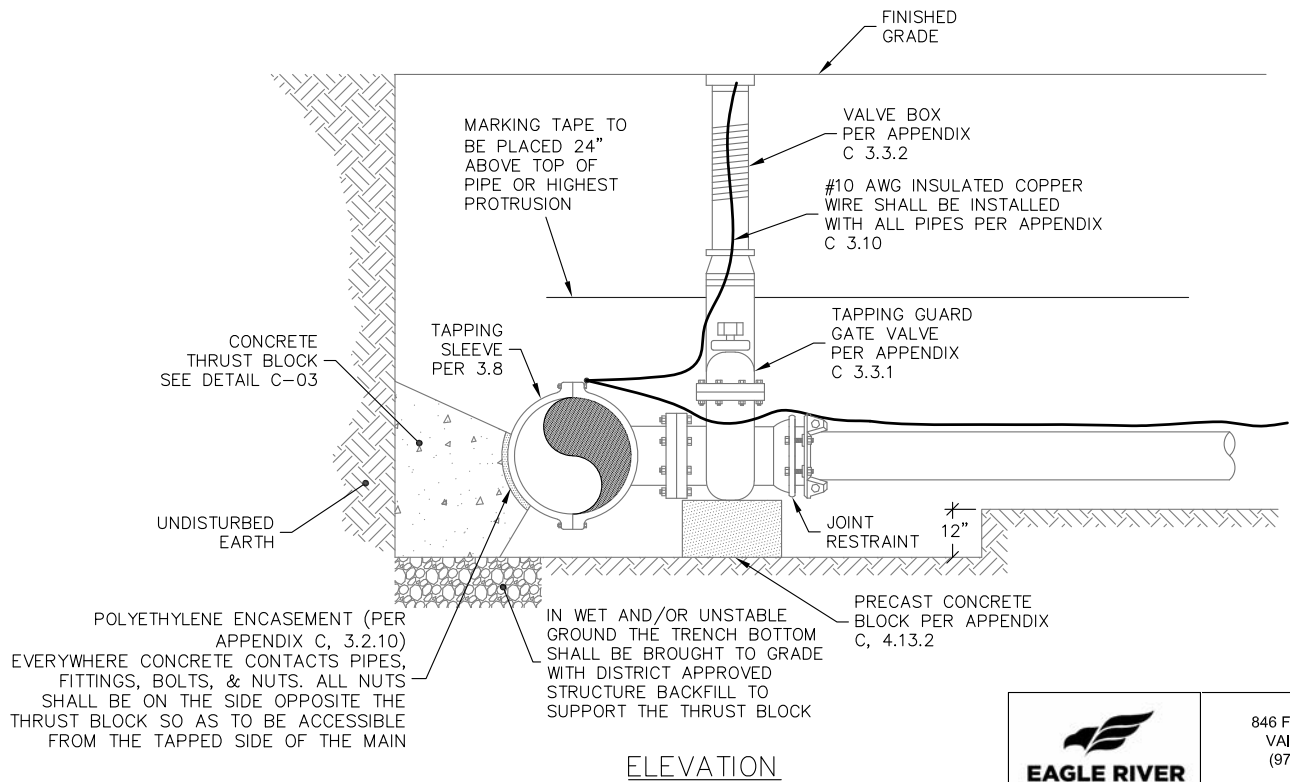

ELEVATION

GENERAL NOTES

1. TAPPING SLEEVES PERMITTED PER APPENDIX B 3.8
2. PRIOR WRITTEN APPROVAL IS REQUIRED BY THE DISTRICT.

	846 FOREST ROAD VAIL, CO 81657 (970) 476-7480
	WWW.ERWSD.ORG

<b>WATER SERVICE TAPPING DETAIL</b>	
DRAWN BY: JEC	DATE: 03/01/2017
SCALE: NONE	REV: N/A
B-02	

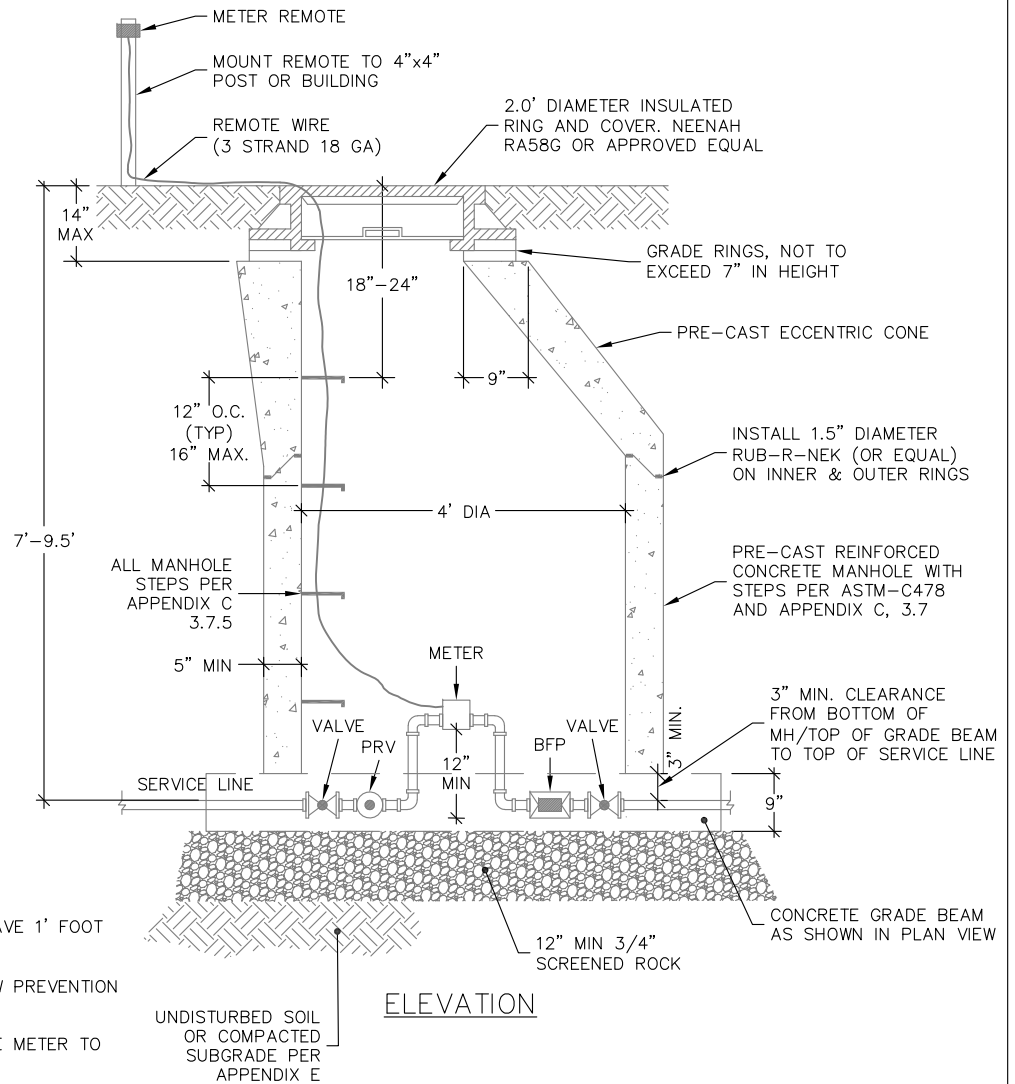
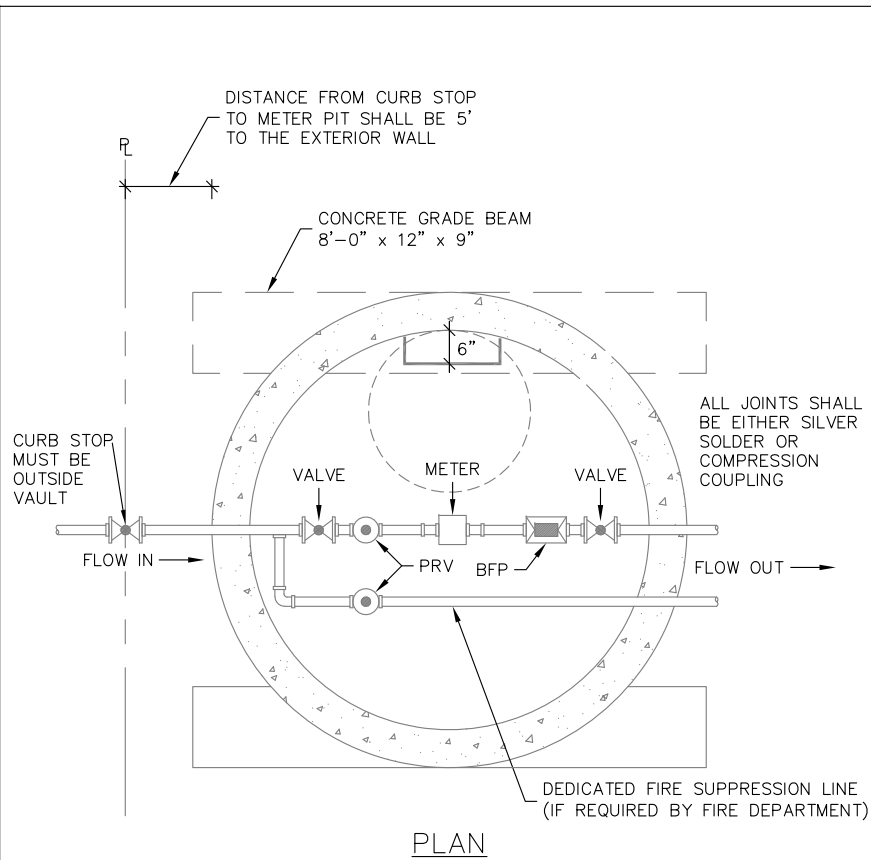

**GENERAL NOTES**

1. THE METER VAULT MUST BE 8' FEET IN DEPTH AND 4' FEET MINIMUM IN WIDTH. IT MUST HAVE 1' FOOT OF 3/4" SCREENED ROCK IN THE BOTTOM OF THE VAULT.
2. ALL COMPONENTS SHALL BE INSTALLED PER DISTRICT STANDARD SPECIFICATIONS. BACKFLOW PREVENTION DEVICE SHALL DRAIN TO DAYLIGHT WHEN APPLICABLE.
3. THE METER MUST BE MOUNTED HORIZONTALLY. THE REMOTE WIRES MUST BE RUN FROM THE METER TO AN OBJECT OUTSIDE THE VAULT (IE. 4"x4" POST, BUILDING, POLE, ECT.).
4. VAULT SHALL BE PRECAST CONCRETE AND CAPABLE OF WITHSTANDING HS 20-44 TRAFFIC LOADING CONDITIONS, IF LOCATION WARRANTS.
5. WHERE PIPES PENETRATE WALLS, USE LINK SEAL OR FILL ANNULAR SPACE WITH NON SHRINK GROUT.
6. CONTRACTOR SHALL SUBMIT VAULT PIPING SCHEMATIC WITH VAULT DIMENSIONS TO DISTRICT PRIOR TO ORDERING MATERIALS OR EQUIPMENT.
7. ALL INSTALLATIONS MUST BE INSPECTED AND APPROVED BY DISTRICT PERSONNEL PRIOR TO BACKFILLING.
8. THIS DETAIL IS APPLICABLE FOR SERVICE LINES SIZES 2" AND UNDER. METER VAULTS FOR 3" AND LARGER SERVICE LINES MUST BE APPROVED BY THE DISTRICT'S CONSTRUCTION REVIEW TEAM PRIOR TO CONSTRUCTION.
9. MULTI-FAMILY, MIXED USE, AND COMMERCIAL METER ASSEMBLIES GREATER THAN 1.5" REQUIRE THE INSTALLATION OF A BYPASS LINE. REFER TO SHEET B-04.

 <b>EAGLE RIVER</b> WATER & SANITATION DISTRICT	<b>SERVICE LINE METER VAULT</b>	
	DRAWN BY: JEC	DATE: 03/01/2017
846 FOREST ROAD VAIL, CO 81657 (970) 476-7480	SCALE: NONE	REV: N/A
WWW.ERWSD.ORG		<b>B-03</b>

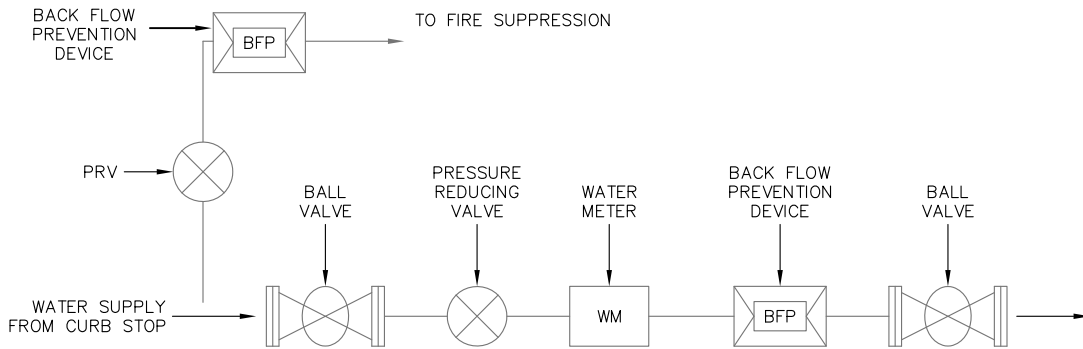

APPROVED METER ASSEMBLY DIAGRAM  
(RESIDENTIAL CONSTRUCTION)

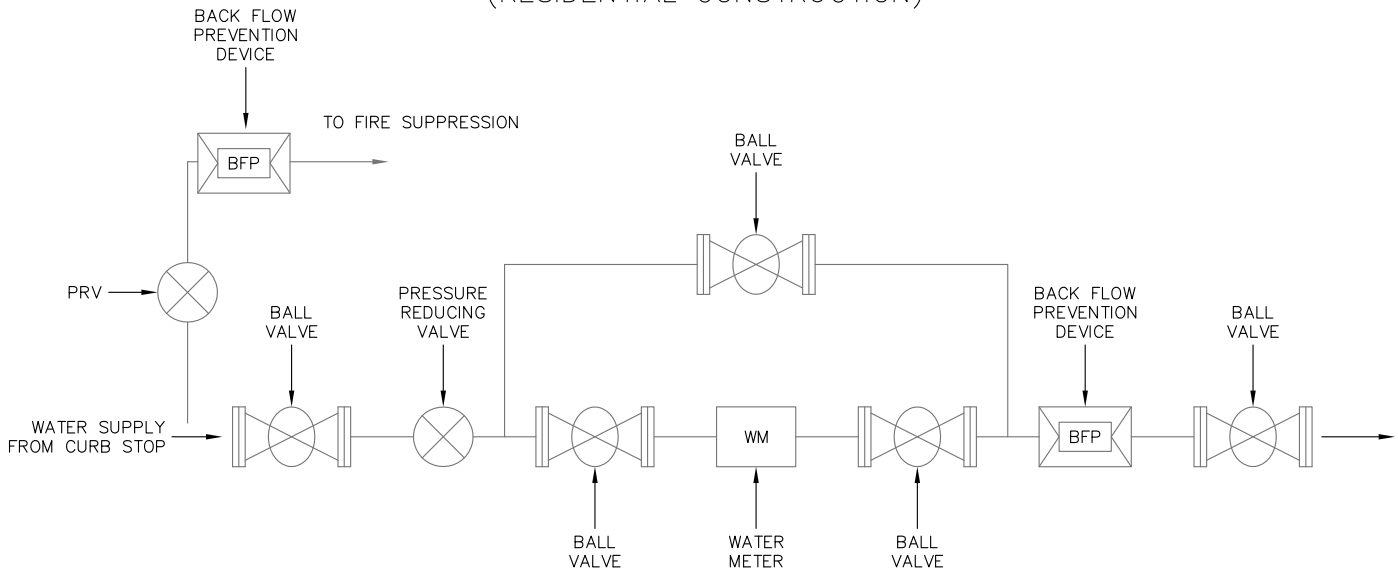

APPROVED METER BYPASS ASSEMBLY DIAGRAM  
(MULTI-FAMILY, MIXED USE, OR COMMERCIAL CONSTRUCTION)

GENERAL NOTES

1. ALL WATER SERVICE INSTALLATIONS MUST CONFORM TO THE ERWSD CURRENT RULES AND REGULATIONS. THE ABOVE DIAGRAMS ARE THE CURRENT APPROVED METERING SYSTEM ASSEMBLIES. DISTRICT NOTIFICATION IS REQUIRED TO OPERATE THE BYPASS.
2. SHUT OFF VALVES MUST BE INSTALLED PRIOR TO THE PRV AND AFTER THE BACKFLOW DEVICE AND/OR METER TO FACILITATE FUTURE REPAIRS.
3. PRESSURE-REDUCING VALVES (PRV) SHALL BE INSTALLED ON BOTH THE DOMESTIC AND FIRE SUPPRESSION SERVICE LINES UPSTREAM OF THE WATER METER TO ENSURE THAT THE WATER METER AND THE BUILDING PLUMBING SYSTEM, INCLUDING ANY FIRE SPRINKLER SYSTEM, ARE PROTECTED FROM FLUCTUATING WATER MAIN PRESSURES. THE PRESSURE SETTING OF THE PRV SHALL NOT EXCEED 100 PSI FOR DOMESTIC SYSTEMS AND 200 PSI FOR FIRE SPRINKLER SYSTEMS, WITHOUT WRITTEN PERMISSION FROM THE DISTRICT. PRV'S REQUIRED ON ALL FIRE SUPPRESSION SYSTEMS UNLESS A VARIANCE IS SIGNED BY THE PROPERTY OWNER.
4. ALL SERVICES ARE REQUIRED TO HAVE A WATER METER PROVIDED BY THE DISTRICT WITH THREE (3) STRAND 18 GAUGE WIRE RUN TO THE FRONT OUTSIDE OF BUILDING FOR REMOTE READOUT (50' SUPPLIED BY DISTRICT). METER INSTALLATIONS SHALL BE NO HIGHER THAN THREE (3) FEET ABOVE AND NO LOWER THAN SIX (6) INCHES ABOVE THE FLOOR LEVEL IN A HORIZONTAL POSITION. IF THE METER IS CURRENTLY LOCATED IN A CRAWL SPACE, THE METER SHALL BE LOCATED WITHIN THREE (3) FEET OF THE ACCESS ENTRY.
5. APPROVED BACKFLOW PREVENTION ASSEMBLIES THAT PROVIDE CONTAINMENT SHALL BE INSTALLED ON ALL NEW SERVICE CONNECTIONS AND SHALL BE LOCATED DOWNSTREAM FROM THE METER PRIOR TO ANY OTHER CONNECTION AND IN A HORIZONTAL POSITION. SINGLE CHECK VALVES ARE NOT CONSIDERED BACKFLOW PREVENTION ASSEMBLIES AND SHALL NOT BE PERMITTED WITHIN THE SERVICE AREA OF THE DISTRICT.

 <b>EAGLE RIVER</b> WATER & SANITATION DISTRICT	846 FOREST ROAD VAL, CO 81657 (970) 476-7480  WWW.ERWSD.ORG
	METER ASSEMBLIES
DRAWN BY: JEC	DATE: 03/01/2017
SCALE: NONE	REV: 8/17/2017
B-04	

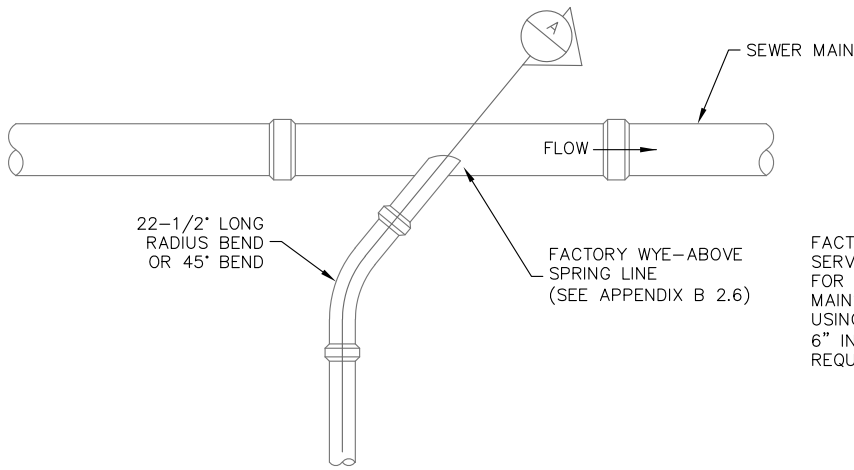

FACTORY WYE SHALL BE INSTALLED FOR SERVICES ON NEW MAINLINE INSTALLATIONS. FOR SERVICE CONNECTIONS TO EXISTING MAINS, TAP TO BE PERFORMED BY DISTRICT USING TAPPING SADDLE FOR SERVICES UP TO 6" IN DIAMETER. SERVICES 8" OR GREATER REQUIRE INSTALLATION OF A MANHOLE.

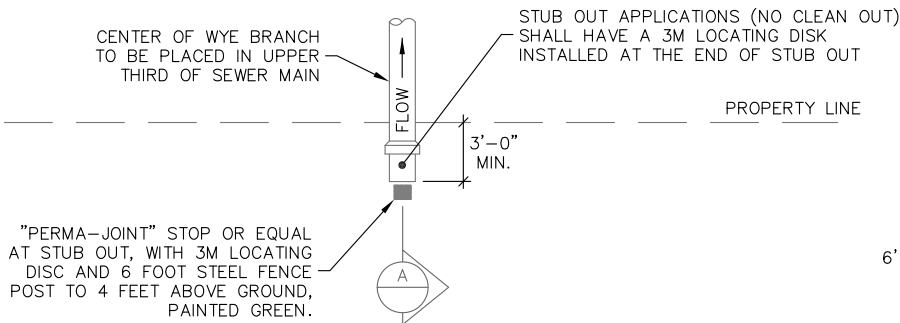

PLAN

CLEANOUTS SHALL CONFORM TO CURRENTLY ADOPTED VERSION OF INTERNATIONAL PLUMBING CODE (IPC) AND ARE REQUIRED WITHIN 3' OF BUILDING FOOTPRINT, AT 100' INTERVALS ON LONGER SERVICES, AND AT CHANGES IN DIRECTION

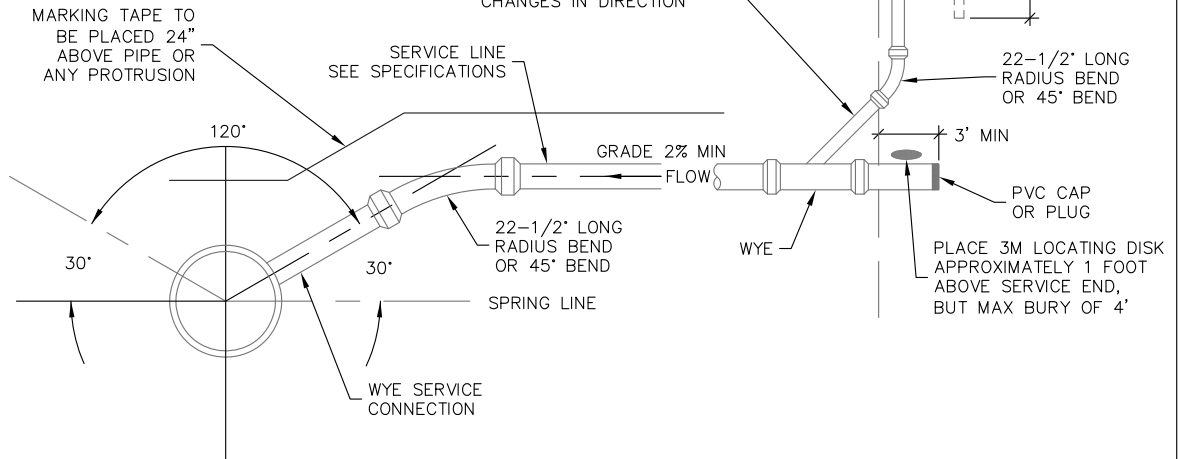

SECTION A

	846 FOREST ROAD VAL, CO 81657 (970) 476-7480
	WWW.ERWSD.ORG

SEWER SERVICE CONNECTION

DRAWN BY: JEC	DATE: 03/01/2017
SCALE: NONE	REV: N/A

B-05

GENERAL NOTES

1. MINIMUM SEPARATION BETWEEN TAPS SHALL BE 18 INCHES.
2. SEWER SERVICE LATERAL CONNECTION SHALL BE 30' TO THE CENTER OF THE SEWER MAIN AND ABOVE SPRING LINE OF THE MAIN.