

PLAN VIEW

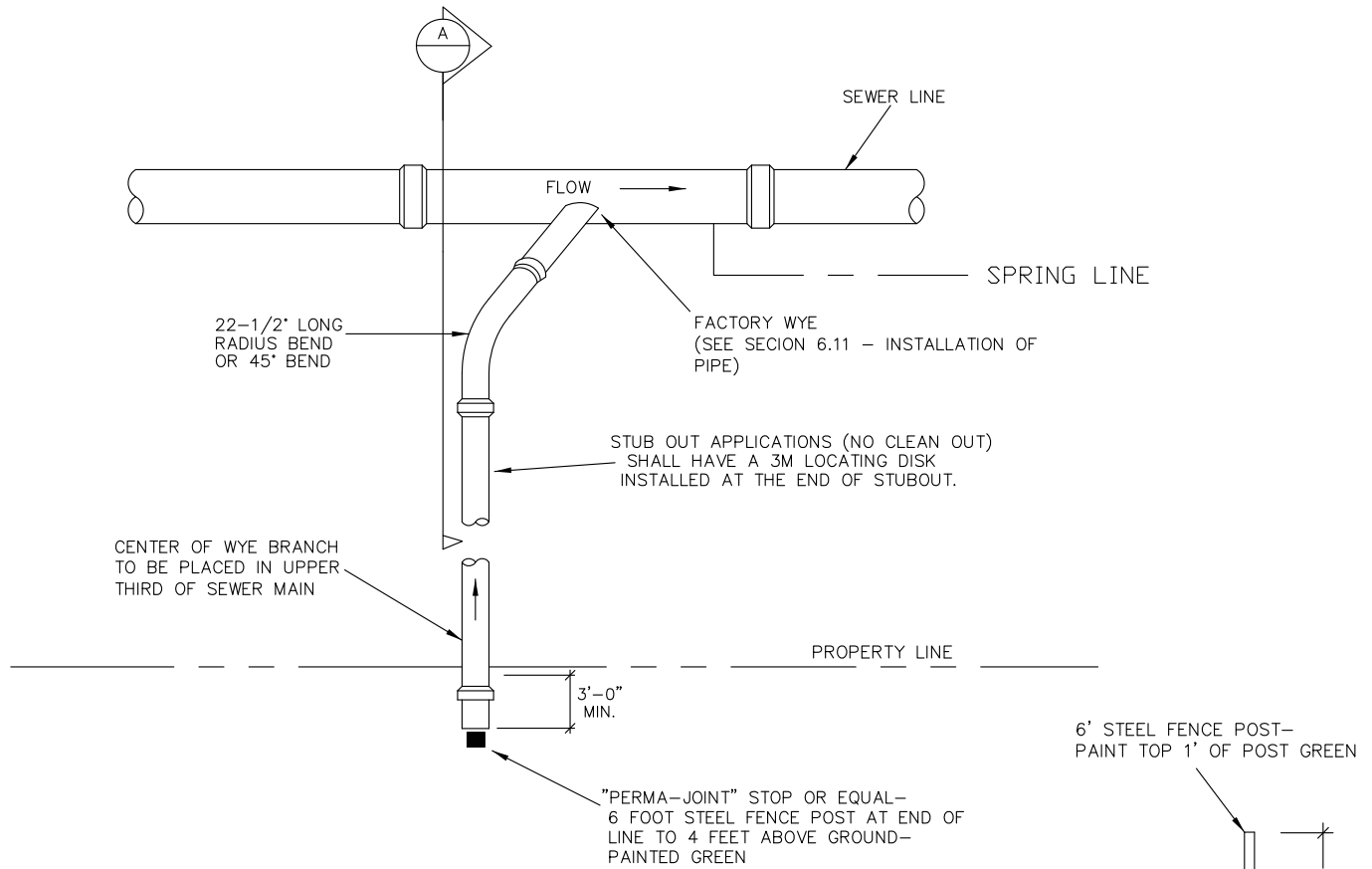

SECTIONAL VIEW

LOCATION TAPE TO BE PLACED 24" ABOVE PIPE OR ANY PROTRUSION

SERVICE LINE-SEE SPECIFICATIONS GRADE = 1/4 INCH PER FOOT MIN.

PLACE 3M LOCATING DISK APPROX. 1 FOOT ABOVE SERVICE END BUT DO NOT BURY AT A DEPTH OF MORE THAN 4'

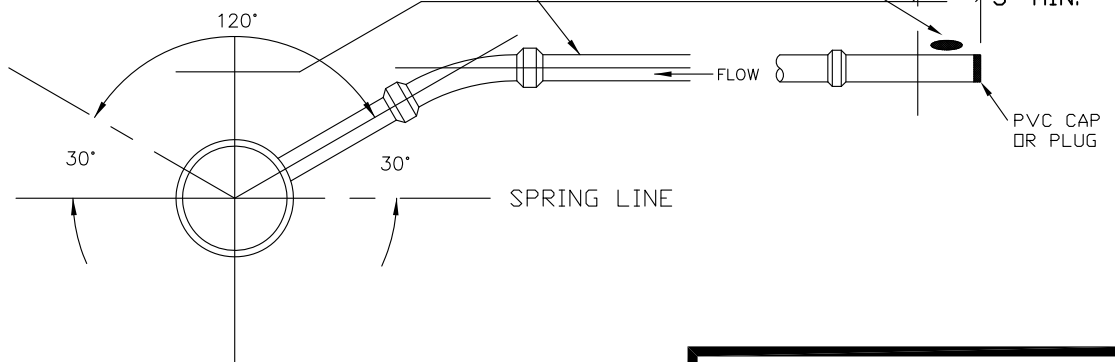

SECTION A

GENERAL NOTE

1. MINIMUM SEPARATION BETWEEN TAPS SHALL BE 18 INCHES.

 EAGLE RIVER WATER & SANITATION DISTRICT	
SEWER SERVICE CONNECTION	
SCALE: NONE	DATE: 01-01-09
REVISIONS: 01-01-06	S-09
APPROVED: FOR YEAR 2009	